



15F1986

# Maintenance Stand



## Building Quality Ground Support Products Since 1961

- Non-slip, self-cleaning steps and platform floor
- Heavy-duty casters and 16" dia. pneumatic tires make it easy to move from job-to-job
- Stair and platform railings can be lifted out and stored on the base
- Base, stairs, and platform stay parallel at any height position
- Options:
  - 4.00 x 8 solid rubber-compound tires
  - Large caster option

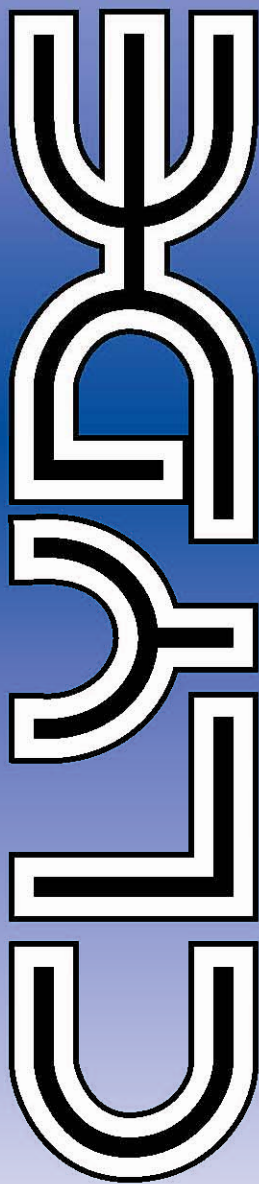

# CLYDE

**Clyde Machines**  
P.O. Box 194  
1150 Hwy 55 N.  
Glenwood, MN 56334 USA  
(320) 634-4504  
(320) 634-4506 Fax

[www.clydemachines.com](http://www.clydemachines.com)

15F1986

# Maintenance Stand

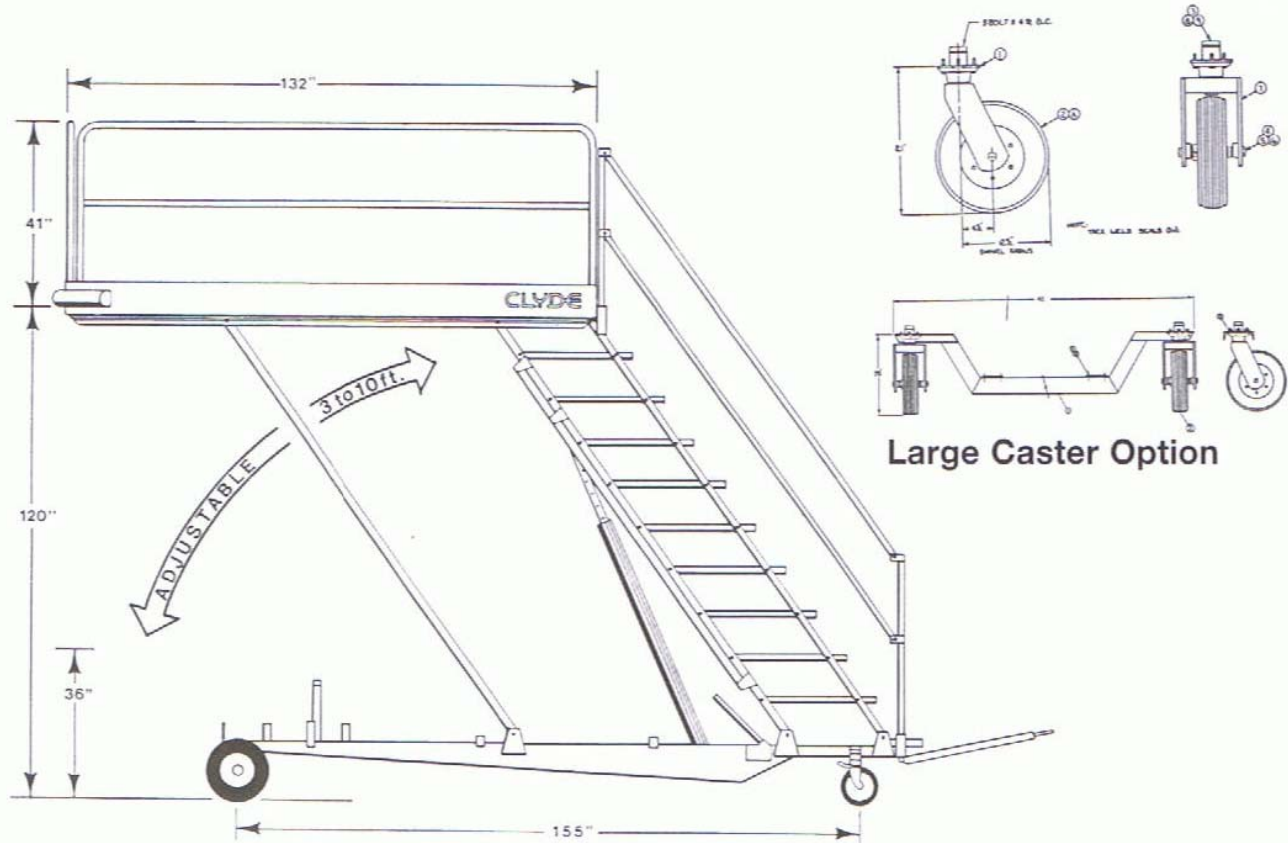

## Shipping Information

- Dimensions:
  - Capacity - 500 lbs
  - Adjustment range - 3' to 10'
  - Working range - 6' to 16'
  - Platform size - 4' x 11'
  - Weight - 1700 lbs
- Shipping Dimensions:
  - Length - 22'
  - Width - 60"
  - Height - 43"

# CLYDE

**Clyde Machines**  
P.O. Box 194  
1150 Hwy 55 N.  
Glenwood, MN 56334 USA  
(320) 634-4504  
(320) 634-4506 Fax

[www.clydemachines.com](http://www.clydemachines.com)